



| | |
|-----------------------------|----------------------------|
| Collection: | HydraSafe (30 hours) |
| Type: | Floating Laminate Flooring |
| System installation: | 5G® FOLD DOWN (by Välinge) |

PLEASE READ THIS ENTIRE DOCUMENT BEFORE PROCEEDING WITH INSTALLATION

Thank you for choosing our flooring product for your project. Before you begin installation, we'd like to draw your attention to an essential feature of our product: it's water-resistant, but not 100% waterproof.

It's crucial to understand the distinction between these two terms. A water-resistant product is designed to repel water when temporary and minor spills or splashes occur, which means it offers some protection against damage from moisture. However, it cannot guarantee total protection from water damage from a large volume of water or exposure to water over a prolonged period of more than 30 hours.

We therefore encourage you to take precautions when installing our product, particular by avoiding the possibility of prolonged contact with stagnant water. If you plan to install this floor in areas subject to frequent spills or high humidity levels, it is your responsibility to choose another flooring product.

TABLE OF CONTENTS

Preparation2

 Product order2

 Product inspection2

 Environment2

 Job site3

 Acclimation3

 Subfloors4

 Installation tools4

Installation5

 Step-by-step5-8

 Dismantling8

Maintenance9

 Cleaning9

 Protection9

Warranty10-12

SECTION 1 – PREPARATION

IMPORTANT: CONDUCT A VISUAL INSPECTION OF THE BOARDS BEFORE INSTALLATION. ONCE INSTALLED, THE BOARDS ARE CONSIDERED ACCEPTED BY BOTH THE INSTALLER AND THE OWNER.

Product Order

When flooring is ordered, a 5% allowance factor, depending on the layout, must be added to the actual square footage amount needed. Diagonal installations may require up to a 10% allowance factor.

Select appropriate underlayments that are no more than 3 mm thick, such as those with a vapour barrier for installation on concrete subfloors.

Product Inspection

The installer is responsible for the final inspection of the entire flooring to judge its quality. This inspection should be done before installation.

The grade, fabrication, surface quality, colour and finish must be carefully examined. With reasonable judgement, put aside or trim boards with small defects, whatever the cause.

If the installer doubts the manufacturing or finishing quality and cannot install the board in a

more inconspicuous place, or eliminate the imperfection, they should not install it. Once the board is installed, it shall be considered as having been accepted by the installer and the owner, even if the latter is absent at the time of installation.

If you consider that the flooring is not acceptable, contact your dealer immediately.

Environment

Before beginning installation, the installer must determine whether the environment of the job site and the condition and type of subfloor are acceptable, ensuring that they meet or exceed all the requirements of the following Goodfellow installation instructions.

Goodfellow accepts no responsibility for job failure resulting from, or associated with, deficiencies in the job site environment or inappropriate or poorly prepared subfloors.

HydraSafe (30 hours) laminate flooring must be installed in an environment with relative humidity between 35% to 55% to prevent certain problems not covered by the warranty (e.g. swelling, delamination). Installing a humidifier or dehumidifier may be necessary, especially if you have a subfloor with a radiant heating system.

Job Site

In a new construction, flooring must be one of the last steps before the work is completed. Flooring should not be **delivered** until the building has been closed in and cement work, plastering, painting and other materials are completely dry. Concrete and plaster should be cured for at least 60 days.

Store flooring in a dry area and not in direct contact with concrete or near exterior walls. Ensure at least 4" of ventilation space under and around boxes.

Handle with care. Do not stand upright on ends.

Inspect basements and crawl spaces to be sure that they are dry and well-ventilated to avoid moisture damage.

All work involving water or moisture, such as plumbing, acoustical ceilings and dry wall taping, should be completed prior to flooring being installed.

Heating and air systems should be fully operating to maintain a consistent room temperature of 16 to 27°C (60 to 80°F) and a constant relative humidity between 35% and 55%.

This laminate flooring can be installed below, at or above ground level. However, follow the applicable regional building codes for installations in bathrooms or other areas as they may not be permitted.

Acclimation

HydraSafe (30 hours) laminate flooring will react to changes in relative humidity levels. In summer, when humidity levels are higher, the floor expands and absorbs moisture. These variations must be minimized with adequate dehumidification.

As for winter, when the heating system is working, the humidity level is lower. It is then recommended to use a humidifier to minimize the contraction.

When the flooring is delivered to your building or room, the boxes must be placed in the installation area. Ensure that the relative humidity level is maintained between 35% and 55%, and leave the flooring left to acclimatize for a minimum of 48 hours.



IMPORTANT: HYDRASAFE CAN BE INSTALLED ON SUBFLOORS EQUIPPED WITH RADIANT HEATING SYSTEMS. HOWEVER, RADIANT HEATING SYSTEMS GENERALLY PRODUCE DRY HEAT THAT CAN REDUCE AMBIENT HUMIDITY. SINCE IT IS CRUCIAL TO MAINTAIN A HUMIDITY LEVEL BETWEEN 35% AND 55% AT ALL TIMES, A HUMIDIFIER MUST BE USED WHEN THE RADIANT HEATING SYSTEM IS IN OPERATION.

Subfloors

APPROVED SUBFLOORS FOR HYDRASAFE FLOATING FLOORS

- Plywood 5/8" – OSB 23/32" (joists of 16" c/c or less)
- Plywood 3/4" – OSB T&G 23/32" (joists of 19.2" c/c or less)
- Concrete with underlayment with a vapour barrier of 6 mil

RADIANT SUBFLOOR HEATING SYSTEM

The radiant heating system must be fully installed and working for at least 7 days prior to installing the floor.

Before laying the flooring, switch off the system and allow the floor to cool to room temperature for approximately 3 to 4 hours. After the floor is laid, switch the system back on immediately and gradually increase the temperature over a period of 6 to 8 hours to the desired level.

The temperature of the flooring surface must never go over 27°C (80°F) for the life of the floor.

SUBFLOOR CONDITIONS

CLEAN: Remove all traces of debris, such as wax, paint, oil, caulking, sealant, adhesive residues from prior flooring installations, and any other contaminants. When preparing the surface, do not use products containing citrus oils, solvents or petroleum, as these can damage or stain the new flooring.

HORIZONTAL/FLAT: The floor must be level with a maximum horizontal tolerance of 4.7 mm over 3 m (3/16" over 10-foot radius) or 3 mm over 2 m (1/8" over 6-foot radius). Sand down high areas and joints to achieve this levelness. Maximum deflection should not exceed 1.1 mm (3/64").

INSTALLATION ON CONCRETE: For concrete subfloors, ensure they have been finished at least 60 days before installation. The internal relative humidity must be less than 80%, and pH level must be between 7 and 9.

POLYFILM TEST DIRECTIONS: Completely tape down 90 cm × 90 cm (3' × 3') polyfilm squares to the concrete subfloor using vapour-barrier tape. Wait 24 hours. If the concrete turns dark or condensation appears on the film, this means that moisture is present, which requires further action.

Installation tools

POWER TOOLS: Table saw, electric miter saw, band saw, circular saw, or jig saw.

HAND TOOLS: Broom and dustpan, or vacuum cleaner, tape measure, moisture meter (for wood, concrete or both), chalk line and chalk, 3M blue tape, hand saw, hammer, rubber mallet, tapping block, pry bar, filler stick and touch-up marker, floor cleaner.

SECTION 2 – STEP-BY-STEP INSTALLATION INSTRUCTIONS

Goodfellow cannot be held responsible and will not assume any labour or installation costs associated with improper installation of its products or poor judgment by the installer.

The 5G® FOLD DOWN locking system by Välinge features a black plastic tab on the short edge of each board:

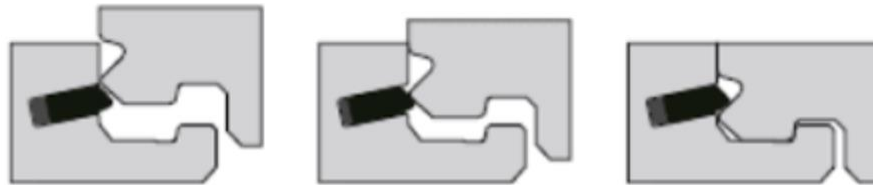

To learn more about how this click system works, scan the QR code and watch the video.

STEP 1 – INSTALL UNDERLAYMENT

Install underlayments approved for 5G® FOLD DOWN floating laminate flooring. The underlayment **should not exceed 3 mm in thickness** *.

* Exceptions: Cork underlayment up to 4 mm is acceptable and Durason 3.5 mm underlayment is acceptable.

Do not apply excessive pad compression or compaction, as this is a common cause of seam failure.

*If installed on concrete, a 6 mil vapour barrier underlayment is required when not using an underlayment with a built-in vapour barrier.

IMPORTANT: The boards must be installed perpendicular to the floor joists.

STEP 2 – PREPARE AND SET UP STARTING ROWS AND ROWS AROUND OBSTACLES

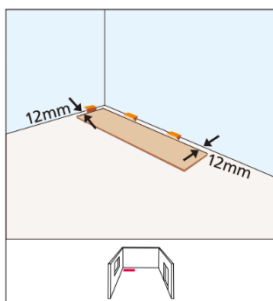

Floating floors require freedom to expand and contract without binding or rubbing on vertical surfaces. It is very important that there be enough expansion gaps between the flooring and all the walls.

Bedrooms and hallways must be isolated from other rooms using transitional mouldings (e.g. bedrooms or living room adjacent to the hallway).

Start at the end wall of the room. This is done by placing 1/2" (12 mm) spacers every 8" (20 cm) apart around all vertical walls.

Kitchen cabinets or islands must be installed on finished floors as this will create pinch points and void the warranty. Leave 1.5 cm (5/8") around **any** obstacle, including fireplaces. Do not exceed 29' 6" (9 m) spans without an expansion joint and transition moulding (see Fig. 1).

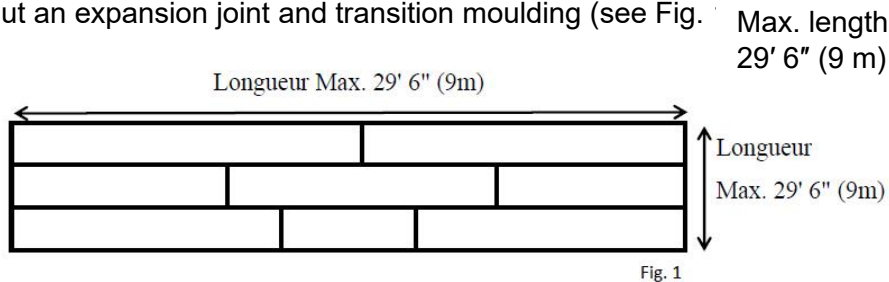

IMPORTANT: Lack of expansion may cause squeaking and sections to pull apart when there is humidity variation due to contact with vertical surfaces.

Measure the width of the room perpendicular to the direction you intend to install the flooring. The last row of flooring should be 1.5" (4 cm) or wider. If it is less, you should use a rip saw to make the starter row narrower. Leave 1/2" (12 mm) between the wall and the end of each strip in each row.

STEP 3 – INSTALLATION



To learn more about the 5G® FOLD DOWN installation, scan the QR code and watch the video.

1. Assemble the ends of the boards by inserting the tongue of one board into the groove of another. Continue laying the boards, working from left to right.

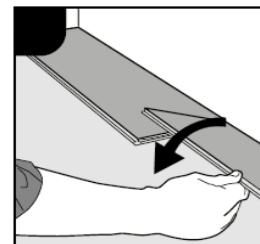

2. To engage the locking system, press the end of the board until you hear a click. A click indicates that the locking system is properly engaged.

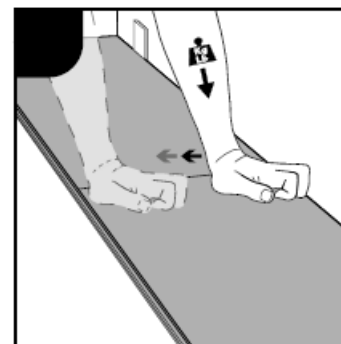

3. Start the second row with a strip at least 6" (15 cm) shorter or longer than the strip used in the first row. This will avoid aligning or clustering the end joints.

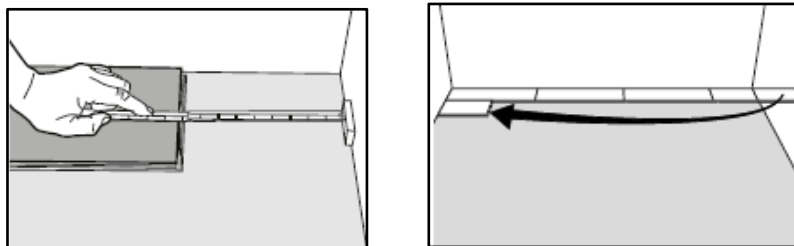

4. Fold the panel down, pressing lightly on the left. Check that the board is well joined to the top one.

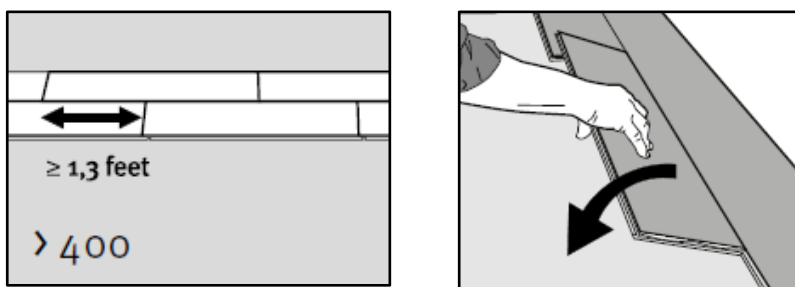

5. Install the next rows.

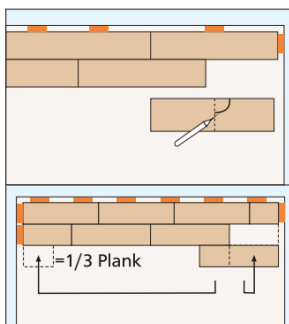

6. The width of the last row must be 1.5" or more (> 50 mm). To do this, place a full row of strips on top of the last row installed. Insert a 1/2" (12 mm) spacer against the wall, and using a full-width strip, trace a line the width of the final row from the wall. Cut strips for the final row to the designated width.

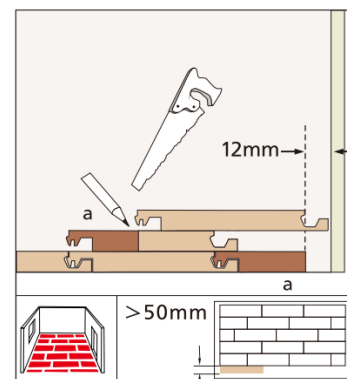

7. Install the transition pieces, baseboards and quarter round mouldings.

To achieve optimum results, make sure that the colours of the mouldings are similar to the colours of the boards that will be installed. Variations in boards and mouldings colours are normal.

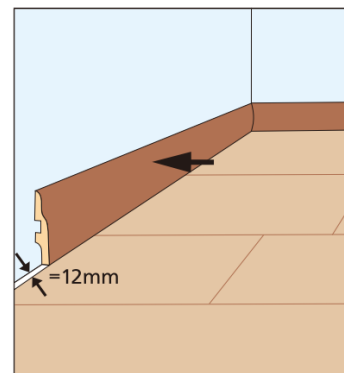

8. Inspect the final floor for nicks or minor gaps and fill with appropriate wood putty of similar colour.

DISMANTLING YOUR FLOOR

Your floor can be easily disassembled, allowing replacement during installation and during use.

1. Separate the whole row by carefully lifting and tapping lightly just above the joint. Fold up and release the whole row.

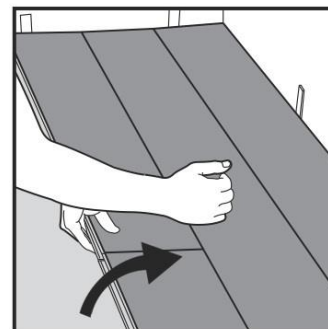

2. Disassemble the panels by sliding horizontally WITHOUT folding them.

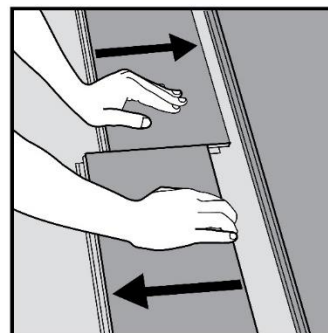

SECTION 3 – MAINTENANCE

CLEANING

- Regularly vacuum (using the hard floor attachment and not the beater bar), dust mop or sweep the floor to prevent sand or abrasive dust from accumulating and scratching the finish.
- Periodically clean the floor with a cleaner specially formulated for laminate flooring. Do not use oil-based cleaners, wax, polish, strong ammoniated or abrasive cleaners, steel wool or scouring powder to clean the floor.
- Do not use any type of polisher.
- Do not wash floors with oil soap or powder detergents. This could cause swelling, warping, delamination and joint-line separation, and void the warranty.
- When washing your floors, don't use too much water or too much cleaner, as an excess could cause swelling, warping or delamination of your floor over the long term and void the warranty.
- Use a damp cloth to blot up spills and spots as soon as they happen. Always avoid allowing liquids to stand on your floor.
- For tough stains from oil, tar, paint, markers, ink, lipstick, cigarettes or other, do a test in an inconspicuous area using acetone or nail polish remover. Wipe immediately with a damp cloth. If the test does not damage the floor, try the treatment on the stain.

PROTECTING

- Use quality area rugs and doormats by outdoor entrance areas to prevent dirt, sand, grit and other substances such as oil, asphalt or driveway sealer from being tracked onto your floor.
- Use floor protectors and wide load-bearing leg bases under your furniture or appliances to minimize indentations and scratches from heavy objects. As a rule of thumb, the heavier the object, the wider the floor protector should be.
- Do not use rubber or foam-backed plastic mats to prevent slippage as they may discolour the floor.
- Don't walk on your floor with stiletto-style heels, spiked golf shoes or cleats; they may cause imperfections in your floor.
- Rearrange area rugs and furniture periodically so the floor can age evenly. Sun exposure can lighten or darken the colour of different floors.
- Use a dolly, plywood > ¼" thick, or hardboard when moving heavy furniture or appliances. Never try to slide or roll heavy objects across the floor.
- Keep pet nails trimmed or consider booties available from pet stores.

SECTION 4 – LIMITED WARRANTY ON HYDRASAFE FLOORING

DAMAGE PROTECTION

HydraSafe laminate flooring offers temporary top-down protection against water damage, providing a safeguard for up to 30 hours. It's important to note that while the flooring is highly resistant to topical moisture during this period, it is not completely waterproof. Beyond the initial 30 hours, there is a risk of permanent damage, and prolonged exposure to water should be avoided to maintain the integrity of the floor.

DURATION AND SCOPE OF WARRANTY

Subject to the terms and conditions of this warranty, Goodfellow Inc. ("Goodfellow") warrants these laminated flooring products in their original manufactured condition to be free from defects in manufacturing and workmanship including assembly dimension and grading.

By purchasing the product, the purchaser accepts the warranty and hereby acknowledges that this warranty is in lieu of all other representations, warranties or conditions, express or implied, statutory or otherwise.

Goodfellow does not grant to any person or entity the authority to create for it any obligation or liability in connection with Goodfellow flooring.

Goodfellow shall not be liable to the customer or any other person for any incidental, special or consequential damages, arising out of a breach of this limited warranty or any implied limited warranty (excluding merchantability). Some states or provinces do not allow the excluding of limitation of incidental or consequential damages, so the above limitations or exclusions may not apply to the purchaser. This warranty gives the customer specific legal rights, which may vary depending on the state or province.

TERMS AND CONDITIONS OF THIS WARRANTY

- This limited warranty is conditional upon compliance with the installation instructions set out in this document, including instructions for protecting the floor against subfloor moisture, and upon compliance with maintenance standards. Failure to comply with these instructions and standards will invalidate the warranty.
- This limited warranty is valid only in North America and the United Kingdom.
- The warranty is not transferable. It extends only to the original retail consumer.
- This limited warranty is conditional upon written notice and supporting documentation being submitted to Goodfellow in accordance with the claims procedure detailed below prior to any repair being made in order to confirm that the product has one of the covered defects. Failure to comply with these requirements will invalidate the warranty.

** Any commercial project equal to or greater than 2,000 square feet of floor space must be pre-approved by the branch manager in writing prior to installation to be eligible for the limited warranty.*

EXCLUSIONS

- If the product is found to be unsatisfactory before installation, for whatever reason, it must not be installed and the building owner must notify your dealer immediately. Installation or use of the product constitutes acceptance of the product by the customer. Goodfellow can in no way be held responsible for any costs or defects arising from the installation or use of a defective or nonconforming product.
- Goodfellow shall not be liable for any consequential or special damages or expenses (material, labour or other) arising from the application of this warranty.
- Defects are evaluated by their visibility from a reasonable vertical distance (standing height) from the floor. Any product deformity that is visible only at a certain angle or certain lighting is not considered a defect and is therefore specifically excluded from this warranty.
- This warranty does not cover any other damage caused by:
 - a. Mishandling, faulty installation, improper storage or faulty building design
 - b. Movement or settling of the structure or subfloor on which the product is installed
 - c. Repairs or modifications to the product
 - d. Excessive or inadequate humidity in the area of use
 - e. Full or partial exposure to sunlight and weather
 - f. Indentation, scratches or damage caused by negligence, moisture, insects, animals, and high-heeled or spiked shoes, or failure to use pads under rolling chairs or other furniture
 - g. Man-made or natural disasters including leaking or broken plumbing, fire, flood, earthquake, or standing water occur during or after installation.
- This warranty specifically excludes all other compensation whatsoever, including labour costs, if necessary, installation or reinstallation costs and other direct or indirect, actual or foreseeable, present or future damage.

CLAIMS PROCEDURE

- This procedure constitutes the only way to make a claim in regards to this limited warranty.
- Before making a claim, please ensure that you have read, understood and followed the installation and maintenance procedures to ensure the validity of your warranty. Any failure covered by this warranty must be reported to the authorized dealer within 30 days of discovery.
- Any claim under this warranty by the purchaser of the product must be made in writing during the warranty period and must include the original purchase invoice or other proof of purchase from the authorized dealer, as well as a description of the problem and a photo or sample clearly showing the warranty problem.
- Following prior written agreement between Goodfellow, the dealer and the product claimant for the resolution of a claim, corrective actions may include:
 - a. A refund equal to the purchase price of the defective strips.
 - b. Product replacement, free of charge, equal to the quantity of product to be replaced.

INSTALLATION, MAINTENANCE AND WARRANTY



- In the event of a claim, the owner assumes all other costs including, but not limited to, labour; installation; removal or replacement of cabinets, appliances, furniture or other fixtures; transportation; and any other costs related to the performance of the work.
- Any agreement between Goodfellow, the dealer and the product claimant to refund, replace or otherwise remedy the product shall constitute a final and complete resolution of all claims under this warranty.